



AUTOCAROUSEL: **Secure Automated Storage**

Heavy-Duty Model Specification Sheet

AutoCarousel™ heavy-duty models provide secure, automated storage for all of your medications. They are easy to use, accurate, and their efficient vertical design ensures maximum storage in a compact footprint.

AutoCarousel™ fits your pharmacy. Its powerful AutoPharm® software is designed to work easily with your current medication wholesaler, and the broad range of AutoCarousels offered by Talyst ensures there is a model and size to suit your unique needs and available floor space.

AutoCarousel is integrated into the complete AutoPharm software-based solution, enabling comprehensive management of your pharmacy inventory from arrival in the pharmacy to delivery to the patient care area.

Improved Patient Safety

- Ensures accurate order filling with Smart Bar™ pick-to-light indicators and bar code verification
- Enables comprehensive, accurate tracking and control of all stored items
- Provides enhanced security with physical barriers and password-protected access

Precise Control and Access

- Ensures organized, accessible storage of heavier items, such as IVs
- On-site assembly and a modular design enables delivery and placement in tight clearances
- Allows emergency access to items via manual hand crank or included power drill
- Includes multiple safeties: E-stop touch bar, infrared photo eyes, access panel interlock switch, and motor overload stop

Enhanced Efficiency

- Allows you to reclaim pharmacy space by decreasing your required storage space by 30% to 50%
- Reduces the number of staff and number of hours required to stock items and fill orders
- Streamlines your returns process; just scan the item, enter the quantity, and scan the light-designated bin to safely return the item

AUTOCAROUSEL: Dimensions

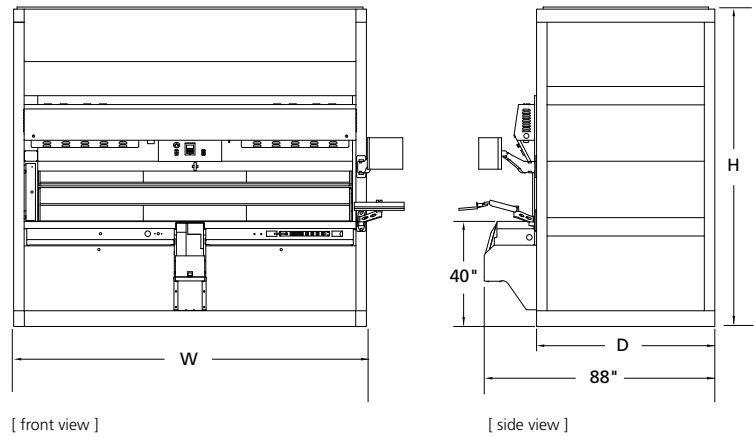

Note: For complete dimensions refer to dimensions chart.

AUTOCAROUSEL: Site Requirements

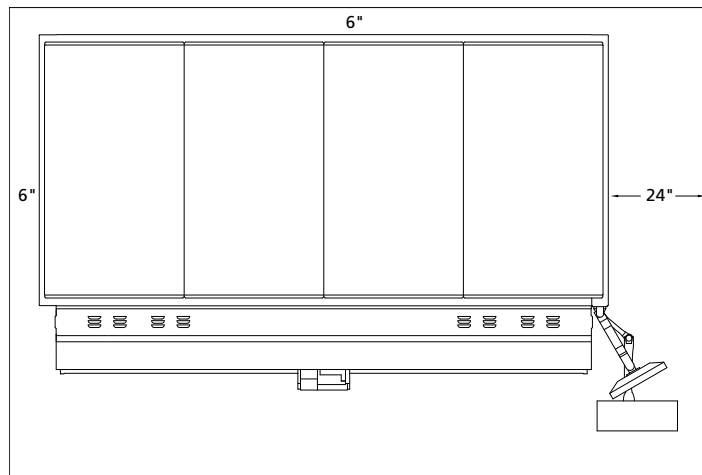

The clearance required for proper operation is 24" on the monitor side, and 6" on the back and non-monitor sides. Additional clearance may be required for maintenance. Actual space required may vary.

Prior to installation, a site survey will be completed to ensure there are no physical obstructions that would affect installation.

AUTOCAROUSEL: Heavy-Duty Model Specifications

DIMENSIONS	TB1060-130	TB1260-130	TB1460-130	TB1660-130	TB1060-112	TB1260-112	TB1460-112	TB1660-112	TB1160-130
Height (H)	96"	108"	120"	132"	96"	108"	120"	132"	102"
Width (W)	154.5"	154.5"	154.5"	154.5"	136.5"	136.5"	136.5"	136.5"	154.5"
Depth* (D)	67.75"	67.75"	67.75"	67.75"	67.75"	67.75"	67.75"	67.75"	67.75"
Carousel Weight w/ Carriers (unloaded)	6226 lbs	7014 lbs	7802 lbs	8590 lbs	5986 lbs	6758 lbs	7530 lbs	8302 lbs	6720 lbs

*Without monitor and counter depth.

STORAGE CAPACITY	TB1060-130	TB1260-130	TB1460-130	TB1660-130	TB1060-112	TB1260-112	TB1460-112	TB1660-112	TB1160-130
Number of Pans	10	12	14	16	10	12	14	16	11
Number of Shelves	20	24	28	32	20	24	28	32	22
Carrier Spacing (Pitch)	12"	12"	12"	12"	12"	12"	12"	12"	12"
Useable Height per Pan	9.87"	9.87"	9.87"	9.87"	9.87"	9.87"	9.87"	9.87"	9.87"
Useable Width per Pan	130"	130"	130"	130"	112"	112"	112"	112"	130"
Useable Depth per Pan	24.5"	24.5"	24.5"	24.5"	24.5"	24.5"	24.5"	24.5"	24.5"
Maximum Load per Pan	600	600	600	600	600	600	600	600	600
Useable Width per Shelf	130"	130"	130"	130"	112"	112"	112"	112"	130"
Useable Depth per Shelf	24.5"	24.5"	24.5"	24.5"	24.5"	24.5"	24.5"	24.5"	24.5"
Useable Unit Cube per Carousel	190 cu ft	229 cu ft	268 cu ft	307 cu ft	165 cu ft	198 cu ft	231 cu ft	264 cu ft	210 cu ft
Storage Area per Carousel	442.4 sq ft	530.8 sq ft	619.3 sq ft	707.8 sq ft	381.1 sq ft	457.3 sq ft	533.5 sq ft	609.8 sq ft	486.5 sq ft

OPERATION	TB1060-130	TB1260-130	TB1460-130	TB1660-130	TB1060-112	TB1260-112	TB1460-112	TB1660-112	TB1160-130
Travel Speed	6.4 inches/sec	6.4 inches/sec	6.4 inches/sec	6.4 inches/sec	6.4 inches/sec	6.4 inches/sec	6.4 inches/sec	6.4 inches/sec	6.4 inches/sec
Average Access Time (1/4 rev)	6.43 sec.	7.38 sec.	8.33 sec.	9.28 sec.	6.43 sec.	7.38 sec.	8.33 sec.	9.28 sec.	6.9 sec.
Maximum Imbalance Load	3000 lbs	3000 lbs	3000 lbs	3000 lbs	3000 lbs	3000 lbs	3000 lbs	3000 lbs	3000 lbs
Drive Type (horsepower)	3	3	3	3	3	3	3	3	5
Work Surface Type	SS	SS	SS	SS	SS	SS	SS	SS	SS
Work Surface Height	40"	40"	40"	40"	40"	40"	40"	40"	40"

FEATURES	TB1060-130	TB1260-130	TB1460-130	TB1660-130	TB1060-112	TB1260-112	TB1460-112	TB1660-112	TB1160-130
Color	Light Grey	Light Grey	Light Grey	Light Grey	Light Grey	Light Grey	Light Grey	Light Grey	Light Grey
Lockable Front Door	Yes	Yes	Yes	Yes	Yes	Yes	Yes	Yes	Yes
Operator Interface	Yes	Yes	Yes	Yes	Yes	Yes	Yes	Yes	Yes
Control Interface (type)	Serial	Serial	Serial	Serial	Serial	Serial	Serial	Serial	Serial
Control Interface Location	Control Panel	Control Panel	Control Panel	Control Panel	Control Panel	Control Panel	Control Panel	Control Panel	Control Panel
Operator Display	Yes	Yes	Yes	Yes	Yes	Yes	Yes	Yes	Yes
Operator Lighting	Fluorescent	Fluorescent	Fluorescent	Fluorescent	Fluorescent	Fluorescent	Fluorescent	Fluorescent	Fluorescent

AUTOCAROUSEL: Heavy-Duty Model Specifications

BINS & DIVIDERS	TB1060-130	TB1260-130	TB1460-130	TB1660-130	TB1060-112	TB1260-112	TB1460-112	TB1660-112	TB1160-130
Arca Tote A - Narrow: 15.7" x 4.5" x 3.9"	-	-	-	-	-	-	-	-	-
Arca Tote A - Wide: 15.7" x 9.1" x 3.9"	-	-	-	-	-	-	-	-	-
Arca Tote B - Narrow: 23.6" x 4.5" x 3.9"	378	438	524	610	332	408	460	536	408
Arca Tote B - Wide: 23.6" x 9.1" x 3.9"	91	117	130	143	84	96	120	132	104
Narrow Bin Divider: 4.5"	1512	1752	2096	2440	1328	1632	1840	2144	1632
Wide Bin Divider: 9.1"	273	351	390	429	252	288	360	396	312

POWER REQUIREMENTS	TB1060-130	TB1260-130	TB1460-130	TB1660-130	TB1060-112	TB1260-112	TB1460-112	TB1660-112	TB1160-130
Main Power	230 VAC 3-Phase 30 amp	230 VAC 3-Phase 30 amp	230 VAC 3-Phase 30 amp	230 VAC 3-Phase 30 amp	230 VAC 3-Phase 30 amp	230 VAC 3-Phase 30 amp	230 VAC 3-Phase 30 amp	230 VAC 3-Phase 30 amp	230 VAC 3-Phase 40 amp
Central Enclosure Duplex & 3-Point Distribution Strip	110 @ 20 amp	110 @ 20 amp	110 @ 20 amp	110 @ 20 amp	110 @ 20 amp	110 @ 20 amp	110 @ 20 amp	110 @ 20 amp	110 @ 20 amp
Duty Cycle	100%	100%	100%	100%	100%	100%	100%	100%	100%
BTU	1908	1908	1908	1908	1908	1908	1908	1908	3180
Decible Level @ 5ft	60dB (A)	60dB (A)	60dB (A)	60dB (A)	60dB (A)	60dB (A)	60dB (A)	60dB (A)	60dB (A)

COMPLIANCE	TB1060-130	TB1260-130	TB1460-130	TB1660-130	TB1060-112	TB1260-112	TB1460-112	TB1660-112	TB1160-130
ETL Certification (complies w/UL)	Yes	Yes	Yes	Yes	Yes	Yes	Yes	Yes	Yes
FCC Certification	Yes	Yes	Yes	Yes	Yes	Yes	Yes	Yes	Yes
OSHPD pre-approval certification	As Required	As Required	As Required	As Required	As Required	As Required	As Required	As Required	As Required

SAFETY	TB1060-130	TB1260-130	TB1460-130	TB1660-130	TB1060-112	TB1260-112	TB1460-112	TB1660-112	TB1160-130
Emergency Hand Crank & Power Drill	Yes	Yes	Yes	Yes	Yes	Yes	Yes	Yes	Yes
E-stop Touch Bar	Yes	Yes	Yes	Yes	Yes	Yes	Yes	Yes	Yes
Infrared Photo Eyes	Yes	Yes	Yes	Yes	Yes	Yes	Yes	Yes	Yes
Access Panel Interlock Switch	Yes	Yes	Yes	Yes	Yes	Yes	Yes	Yes	Yes
Motor Overload	Yes	Yes	Yes	Yes	Yes	Yes	Yes	Yes	Yes