



## AUTOCAROUSEL: **Secure Automated Storage**

### **Narrow Model** Specification Sheet

**AutoCarousel™** narrow models provide secure, automated storage for all of your medications. They are easy to use, deliver precise control, and their narrower design ensures maximum storage in smaller spaces.

**AutoCarousel™ fits your pharmacy.** Its powerful AutoPharm® software is designed to work easily with your current medication wholesaler, and the broad range of AutoCarousels offered by Talyst ensures there is a model and size to suit your unique needs and available floor space.

**The narrower AutoCarousel** is integrated into the complete AutoPharm software-based solution, enabling comprehensive management of your pharmacy inventory from arrival in the pharmacy to delivery to the patient care area.

### Improved Patient Safety

- Ensures accurate order filling with Smart Bar™ pick-to-light indicators and bar code verification
- Enables comprehensive, accurate tracking and control of all stored items
- Provides enhanced security with physical barriers and password-protected access

### Precise Control and Access

- On-site assembly and a modular design enables delivery and placement in tight clearances
- Allows emergency access to items via manual hand crank or included power drill
- Includes multiple safeties: E-stop touch bar, infrared photo eyes, access panel interlock switch, and motor overload stop

### Enhanced Efficiency

- Allows you to reclaim pharmacy space by decreasing your required storage space by 30% to 50%
- Reduces the number of staff and number of hours required to stock items and fill orders
- Streamlines your returns process; just scan the item, enter the quantity, and scan the light-designated bin to safely return the item

## AUTOCAROUSEL: Dimensions

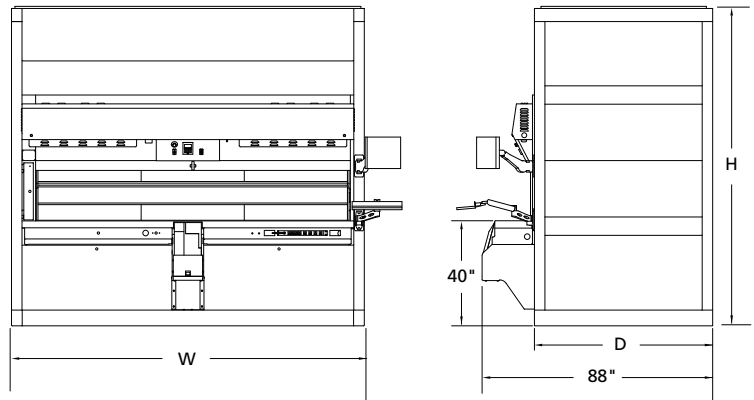

[ front view ]

[ side view ]

Note: For complete dimensions refer to dimensions chart.

## AUTOCAROUSEL: Site Requirements

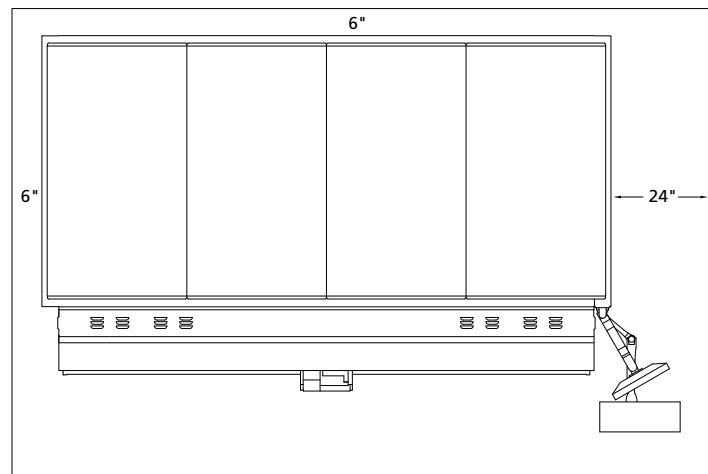

The clearance required for proper operation is 24" on the monitor side, and 6" on the back and non-monitor sides. Additional clearance may be required for maintenance. Actual space required may vary.

Prior to installation, a site survey will be completed to ensure there are no physical obstructions that would affect installation.

## AUTOCAROUSEL: Narrow Model Specifications

| DIMENSIONS                             | 271210-2 | 271212-2 | 271214-2 | 271216-2 | 271514-2 |
|--|----------|----------|----------|----------|----------|
| Height (H)                             | 89"      | 101"     | 113"     | 125"     | 136"     |
| Width (W)                              | 118.5"   | 118.5"   | 118.5"   | 118.5"   | 118.5"   |
| Depth* (D)                             | 64"      | 64"      | 64"      | 64"      | 64"      |
| Carousel Weight w/ Carriers (unloaded) | 4300 lbs | 4580 lbs | 4860 lbs | 5140 lbs | 6300 lbs |

\*Without monitor and counter depth.

| STORAGE CAPACITY               | 271210-2    | 271212-2    | 271214-2    | 271216-2    | 271514-2    |
|--------------------------------|-------------|-------------|-------------|-------------|-------------|
| Number of Pans                 | 10          | 12          | 14          | 16          | 14          |
| Number of Shelves              | 20          | 24          | 28          | 32          | 28          |
| Carrier Spacing (Pitch)        | 12"         | 12"         | 12"         | 12"         | 15"         |
| Useable Height per Pan         | 10.06"      | 10.06"      | 10.06"      | 10.06"      | 13.06"      |
| Useable Width per Pan          | 102"        | 102"        | 102"        | 102"        | 102"        |
| Useable Depth per Pan          | 24.5"       | 24.5"       | 24.5"       | 24.5"       | 24.5"       |
| Maximum Load per Pan           | 400 lbs     | 400 lbs     | 400 lbs     | 400 lbs     | 400 lbs     |
| Useable Width per Shelf        | 102"        | 102"        | 102"        | 102"        | 102"        |
| Useable Depth per Shelf        | 24.5"       | 24.5"       | 24.5"       | 24.5"       | 24.5"       |
| Useable Unit Cube per Carousel | 146 cu ft   | 175 cu ft   | 204 cu ft   | 233 cu ft   | 264 cu ft   |
| Storage Area per Carousel      | 347.1 sq ft | 416.5 sq ft | 485.9 sq ft | 555.3 sq ft | 485.9 sq ft |

| OPERATION                     | 271210-2     | 271212-2     | 271214-2     | 271216-2     | 271514-2     |
|-------------------------------|--------------|--------------|--------------|--------------|--------------|
| Travel Speed                  | 5 inches/sec | 5 inches/sec | 5 inches/sec | 5 inches/sec | 5 inches/sec |
| Average Access Time (1/4 rev) | 7.75 sec.    | 8.95 sec.    | 10.15 sec.   | 11.35 sec.   | 12.25 sec.   |
| Maximum Imbalance Load        | 1220 lbs     | 1220 lbs     | 1220 lbs     | 1220 lbs     | 1220 lbs     |
| Drive Type (horsepower)       | 2            | 2            | 2            | 2            | 2            |
| Work Surface Type             | SS           | SS           | SS           | SS           | SS           |
| Work Surface Height           | 40"          | 40"          | 40"          | 40"          | 40"          |

| FEATURES                   | 271210-2      | 271212-2      | 271214-2      | 271216-2      | 271514-2      |
|----------------------------|---------------|---------------|---------------|---------------|---------------|
| Color                      | Light Grey    | Light Grey    | Light Grey    | Light Grey    | Light Grey    |
| Lockable Front Door        | Yes           | Yes           | Yes           | Yes           | Yes           |
| Operator Interface         | Yes           | Yes           | Yes           | Yes           | Yes           |
| Control Interface (type)   | Serial        | Serial        | Serial        | Serial        | Serial        |
| Control Interface Location | Control Panel | Control Panel | Control Panel | Control Panel | Control Panel |
| Operator Display           | Yes           | Yes           | Yes           | Yes           | Yes           |
| Operator Lighting          | Fluorescent   | Fluorescent   | Fluorescent   | Fluorescent   | Fluorescent   |

## AUTOCAROUSEL: Narrow Model Specifications

| <b>BINS &amp; DIVIDERS</b>                   | <b>271210-2</b> | <b>271212-2</b> | <b>271214-2</b> | <b>271216-2</b> | <b>271514-2</b> |
|--|-----------------|-----------------|-----------------|-----------------|-----------------|
| Arca Tote A - Narrow:<br>15.7" x 4.5" x 3.9" | -               | -               | -               | -               | -               |
| Arca Tote A - Wide:<br>15.7" x 9.1" x 3.9"   | -               | -               | -               | -               | -               |
| Arca Tote B - Narrow:<br>23.6" x 4.5" x 3.9" | 300             | 348             | 416             | 464             | 416             |
| Arca Tote B - Wide:<br>23.6" x 9.1" x 3.9"   | 70              | 90              | 100             | 120             | 100             |
| Narrow Bin Divider: 4.5"                     | 1200            | 1392            | 1664            | 1856            | 1664            |
| Wide Bin Divider: 9.1"                       | 210             | 270             | 300             | 360             | 300             |

| <b>POWER REQUIREMENTS</b>                                | <b>271210-2</b>                  | <b>271212-2</b>                  | <b>271214-2</b>                  | <b>271216-2</b>                  | <b>271514-2</b>                  |
|--|----------------------------------|----------------------------------|----------------------------------|----------------------------------|----------------------------------|
| Main Power   | 208-230 VAC<br>1-Phase<br>20 amp | 208-230 VAC<br>1-Phase<br>20 amp | 208-230 VAC<br>1-Phase<br>20 amp | 208-230 VAC<br>1-Phase<br>20 amp | 208-230 VAC<br>1-Phase<br>20 amp |
| Central Enclosure Duplex &<br>3-Point Distribution Strip | 110 @<br>20 amp                  | 110 @<br>20 amp                  | 110 @<br>20 amp                  | 110 @<br>20 amp                  | 110 @<br>20 amp                  |
| Duty Cycle   | 100%                             | 100%                             | 100%                             | 100%                             | 100%                             |
| BTU  | 1272                             | 1272                             | 1272                             | 1272                             | 1272                             |
| Decibel Level @ 5 ft                                     | 60dB (A)                         | 60dB (A)                         | 60dB (A)                         | 60dB (A)                         | 60dB (A)                         |

| <b>COMPLIANCE</b>                 | <b>271210-2</b> | <b>271212-2</b> | <b>271214-2</b> | <b>271216-2</b> | <b>271514-2</b> |
|-----------------------------------|-----------------|-----------------|-----------------|-----------------|-----------------|
| ETL Certification (complies w/UL) | Yes             | Yes             | Yes             | Yes             | Yes             |
| FCC Certification                 | Yes             | Yes             | Yes             | Yes             | Yes             |
| OSHDP pre-approval certification  | As Required     | As Required     | As Required     | As Required     | As Required     |

| <b>SAFETY</b>                      | <b>271210-2</b> | <b>271212-2</b> | <b>271214-2</b> | <b>271216-2</b> | <b>271514-2</b> |
|------------------------------------|-----------------|-----------------|-----------------|-----------------|-----------------|
| Emergency Hand Crank & Power Drill | Yes             | Yes             | Yes             | Yes             | Yes             |
| E-stop Touch Bar                   | Yes             | Yes             | Yes             | Yes             | Yes             |
| Infrared Photo Eyes                | Yes             | Yes             | Yes             | Yes             | Yes             |
| Access Panel Interlock Switch      | Yes             | Yes             | Yes             | Yes             | Yes             |
| Motor Overload                     | Yes             | Yes             | Yes             | Yes             | Yes             |